

PROLINE

# PROCHANNEL

THE JOY OF SHOWERING  
WITH PERFECT FLOOR-LEVEL SHOWERS.



# Convenient

## Linear drainage system from Proline

Floor-level showers have emerged as a central highlight in contemporary bathroom aesthetics and have become rooms within rooms. Drainage systems have also adapted to meet this trend towards design-oriented accents.

In the past, tiles were applied to the shower surface around a point drainage system usually located in the centre of the shower, but state-of-the-art line drainage systems have now done away with these design and construction-related constraints. The slope no longer needs to lead from four sides to one drainage point. Beyond its appealing visual aspects, the slope for PROCHANNEL along the floor of your shower provides a comfortable position with even water flow.

As a result, the design of the linear drainage system makes a significant contribution to giving tiled, floor-level showers their striking visual appearance. The less the floor covering is broken up by joints and visible drainage features, the more pronounced the effect on enhancing the appearance of the room.

The PROCHANNEL linear drainage system provides you with a sophisticated, tried-and-tested system that gives you more than just the choice between primary and secondary drainage. The creative variety provided by various design grilles and the use of tile recesses for exceptionally subtle integration ensure all of your design aspirations are fulfilled. You will be awash in amazement!



## Advantages of the linear drainage system

- Almost limitless design freedom
- Custom design variants
- Aesthetic and convenient
- Timeless and design oriented
- Accessible and approved



# PROCHANNEL Drainage systems

## Advantages of linear drainage from Proline

Floor-level showers offer comfort free of compromises. This includes an elegant, timeless drainage system that meets the highest requirements with its function and sophisticated technology.

The visionary ideas behind the PROCHANNEL linear drainage system make it one of a kind. The modular system draws appeal in private homes as well as hotels and public buildings.



### PROCHANNEL Linear drainage

- Individual kit system
- Ideal for large tile formats and natural stone floors
- Suitable for installation by a wall, in the centre or at the entrance to the shower
- Flange for sealing that is compliant with standards
- Low installation height (starting at 52 mm)
- Drainage line housing of high-quality stainless steel
- Hygienic and easy to clean
- Five different drain pans
- Drain pans can be rotated variably up to 360°
- Tested sealing system with abP (= General Building Test certificate)
- Tested sound protection surveys up to SST III

## Flexible modular system

### **PROCHANNEL***p-line*

Primary drainage

### **PROCHANNEL***s-line*

Primary and secondary drainage

Whether you decide on the PROCHANNELp-line with primary drainage or the PROCHANNELs-line with primary and secondary drainage, both drainage line systems will meet all your design needs. Together with our drain pans and tested seals, we have created a modular system with one-of-a-kind flexibility and design possibilities.

## Accessories in the system

Our accessories ensure you have everything you need for installation right on site. And what is most important: All of the individual drainage and sealing system parts fit together perfectly and guarantee optimal results.



# The choice is yours

## PROCHANNEL<sup>p</sup>-line



PROCHANNEL<sup>p</sup>-line with Classic design grille made of stainless steel

- With fixed frame for tile flooring up to 12.5 mm thick
- With fixed frame for natural stone flooring 15 mm or 20 mm thick
- Seven different covers
- Custom solutions available on request

### Primary drainage

The linear drainage system captures surface water over its entire length and channels the water away. The water drains over the surface of the floor covering and into the drainage line housing. The enclosed drainage line housing ensures this variant provides

absolute hygienic reliability. The one-sided slope is created easily and effectively. Installation is easy and requires taking the needs of heat insulation and walking/impact noise into account.

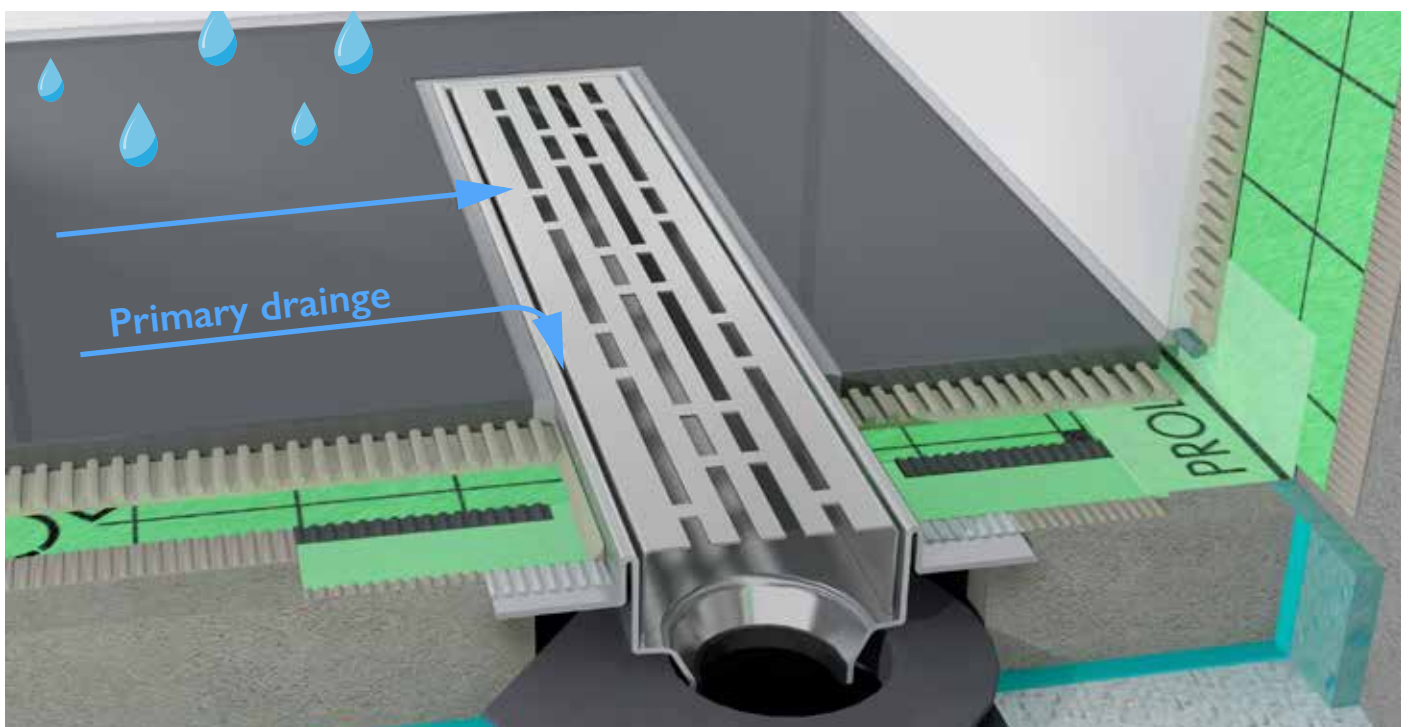

## PROCHANNELS-line

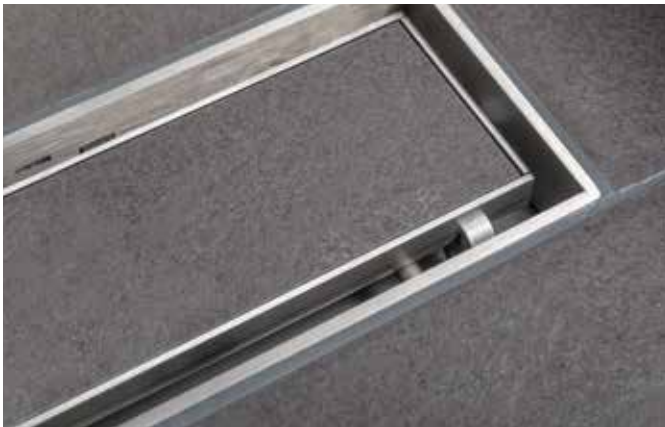

PROCHANNELS-line with an elegant shadow gap

- With 4-way adjustable frame for flooring of 10–17 mm
- Seven different covers
- Additional option for installation with elegant shadow gap
- Ideal for natural stone flooring

### Primary and secondary drainage

This version of the linear drainage system captures surface water over its entire length and channels the water away. Not only water on the surface of the floor covering drains away, but any seep water accumulating in the bonding gap can drain

into the drainage line housing through the sealing level as well. Installation is easy and requires taking the needs of heat insulation and walking/impact noise into account.

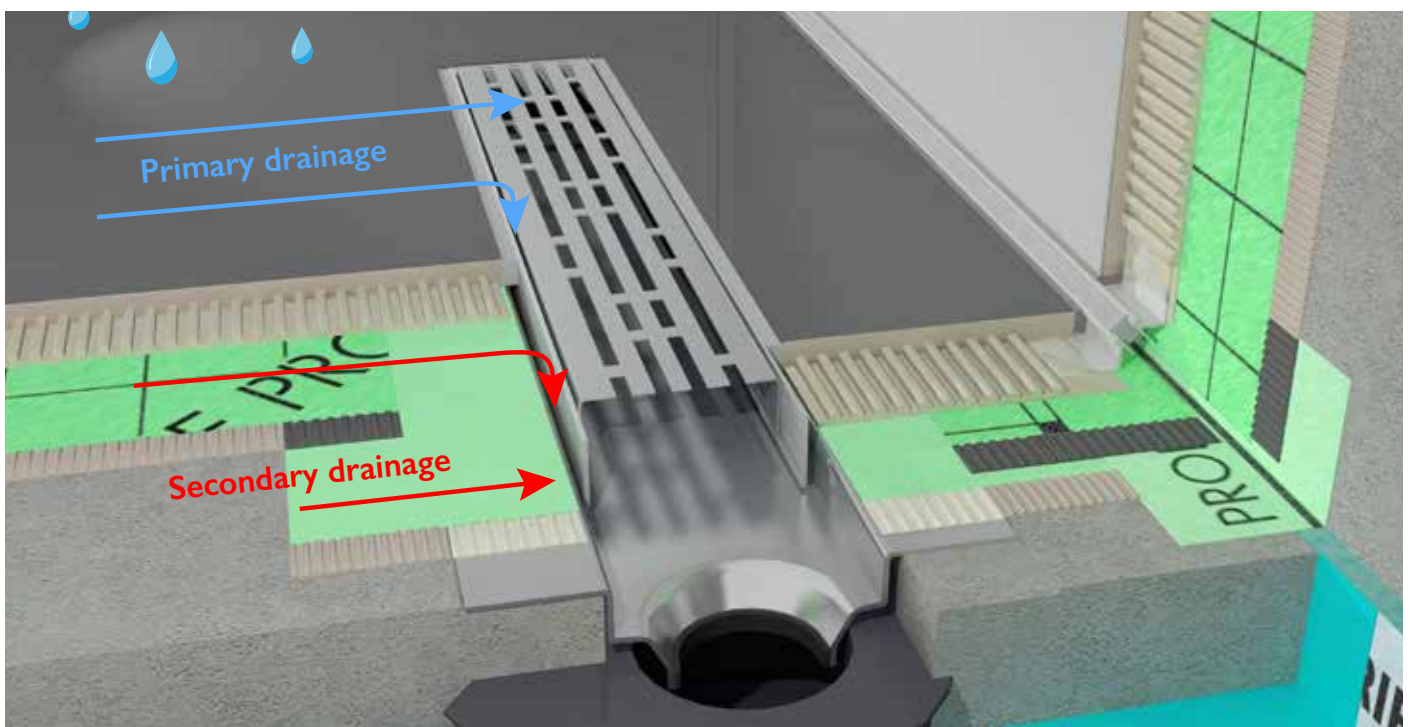

## Flexible modular system

PROCHANNEL *p-line* with design grille

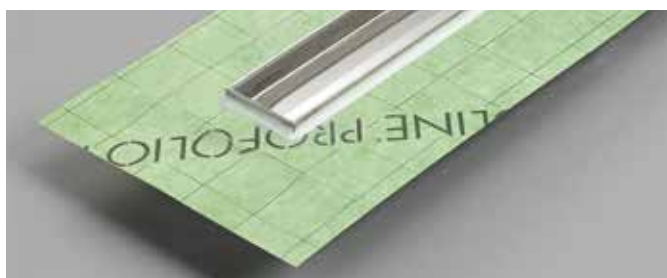
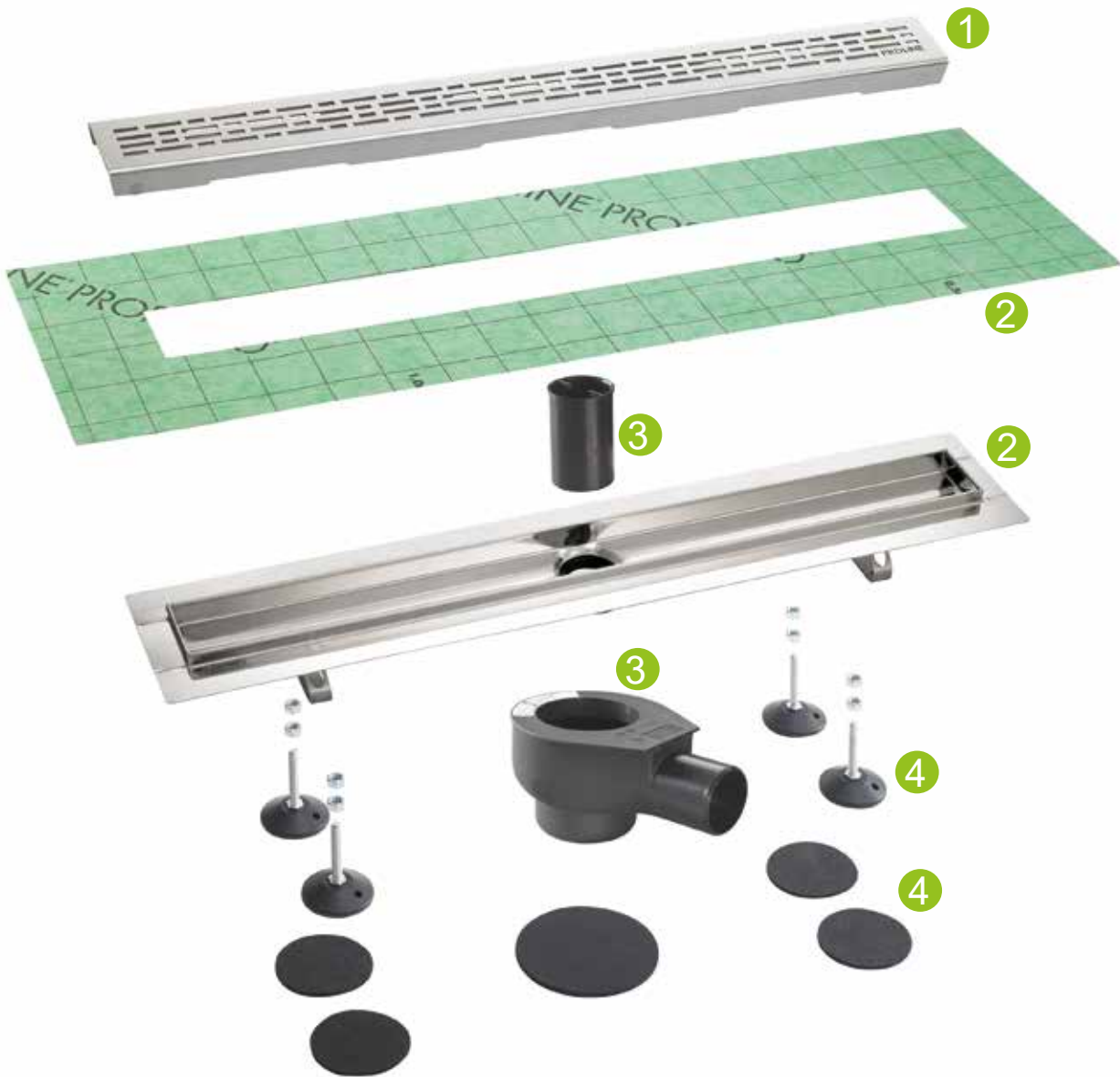

\*Additional alternative: with permanently bonded sealing collar

1. PROCHANNEL design grille Classic  
Alternatively, see other drainage covers (P. 14)
2. PROCHANNEL p-line drainage line housing for tiles  
with separately packed sealing collar\*
3. PROCHANNEL drain fitting with trap (p. 13)
4. PROCHANNEL installation feet and noise-insulating pads

## PROCHANNELs-line with design grille

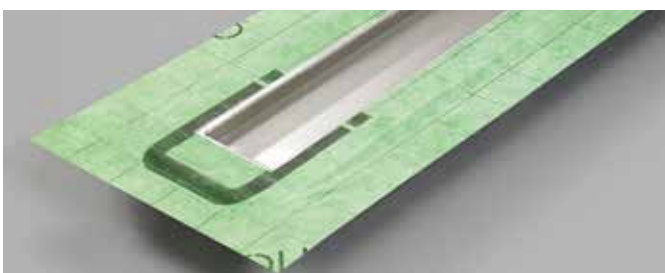

\*Additional alternative: with permanently bonded sealing collar

1. PROCHANNEL design grille Classic  
Alternatively, see other drainage covers (P. 14)
2. PROCHANNELs-line frames
3. PROCHANNELs-line drainage line housing  
with separately packed sealing collar\*
4. PROCHANNEL drain fitting with trap (p. 13)
5. PROCHANNEL installation feet and noise-insulating pads

## Flexible modular system

PROCHANNELs-line with support element

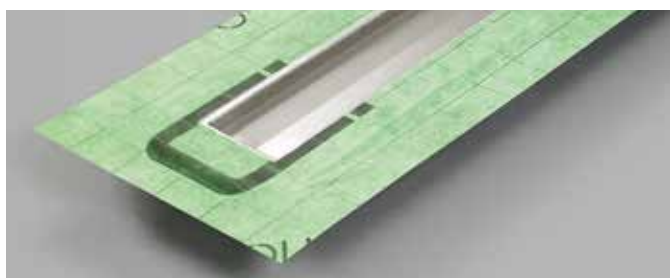

\*Additional alternative: with permanently bonded sealing collar

1. PROCHANNELs-line support element for creating a shadow gap (p. 15)
3. PROCHANNELs-line drainage line housing with separately packed sealing collar\*
4. PROCHANNEL drain fitting with trap (p. 13)
4. PROCHANNEL installation feet and noise-insulating pads

## PROCHANNELS-line with EPS carrier and tile recess



### 1. PROCHANNEL tile recess

Alternatively, see other drainage covers (P. 14) and PROCHANNELS-line support element (in this event the frame at Point 2 is not required)

### 2. PROCHANNELS-line frames

3. PROCHANNELS-line drainage line housing with EPS carrier and permanently bonded sealing collar incl. drain fitting with trap (Item No. 95340)

# System packages

## PROCHANNELs-line

**PROCHANNEL**  
system packages  
pre-configured  
for you



- 1. PROCHANNEL tile recess
- 2. PROCHANNELs-line frames
- 3. PROCHANNELs-line drainage line housing with permanently bonded sealing collar
- 4. PROCHANNEL drain fitting with trap (p. 13)
- 5. PROCHANNEL installation feet and noise-insulating pads

## Drain fittings

### PROCHANNEL *p-line* & PROCHANNEL *s-line*

A selection of five drain pans to meet any requirements is available to complete the modular system:

- Freely selectable drain pans to adapt to the installation height
- Direct alignment with the house connection
- Rotatable by 360° except superflat drain pan

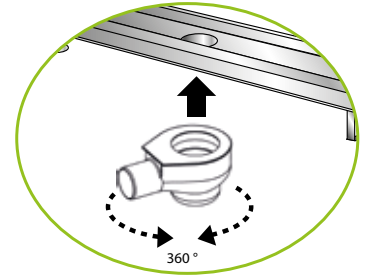

### PROCHANNEL drain fittings

For rotational assembly on drainage line housing

#### Horizontal connection

Maximum drainage	0.7 l/s	0.8 l/s	1.2 l/s
Connection	DN 50	DN 50	DN 70
Standard-compliant drainage	-	Yes	Yes
Installation height min. (mm)*	81	106	134
Installation height min. (mm)**	84	110	138
Sealing water height (mm)	25	50	60
Item No.	95340	95341	95344



0,7 l/s / DN 50



0,8 l/s / DN 50



1,2 l/s / DN 70

### PROCHANNEL drain fitting

For rotational assembly on drainage line housing

#### Vertical connection

Maximum drainage	1.3 l/s
Connection	DN 50
Standard-compliant drainage	Yes
Installation height min. (mm)*	14 / 52 without/with base holder
Installation height min. (mm)**	17 / 52 without/with base holder
Sealing water height (mm)	50
Item No.	95342



### PROCHANNEL drain fitting, super flat

Drain fitting made from plastic, compatible with all PROCHANNEL drainage lines with particularly low installation height

#### Side connection

Maximum drainage	0.5 l/s
Connection	DN 40
Standard-compliant drainage	-
Installation height min. (mm)*	55
Installation height min. (mm)**	59
Sealing water height (mm)	30
Item No.	95343



\* Minimum installation height (mm) refers to installation with PROCHANNEL *p-line* (measured up to fixed flange)

\*\* Minimum installation height (mm) refers to installation with PROCHANNEL *s-line* (measured up to fixed flange)

Please note: Observe the fixed frame height on PROCHANNEL *p-line* of 15 mm for tiles as well as 20 and 25 mm for natural stone

# Drainage line covers

## PROCHANNEL<sub>p-line</sub> & PROCHANNEL<sub>s-line</sub>

### Tile recess or design grilles

The tile recess makes it possible to provide a visual adjustment to match tile flooring. Or you can decide on a design grille of stainless steel to act as a contrast to your tile. The drainage lines

are designed so that the tile recesses and design grilles can be used in both variants. Special solutions available upon request.

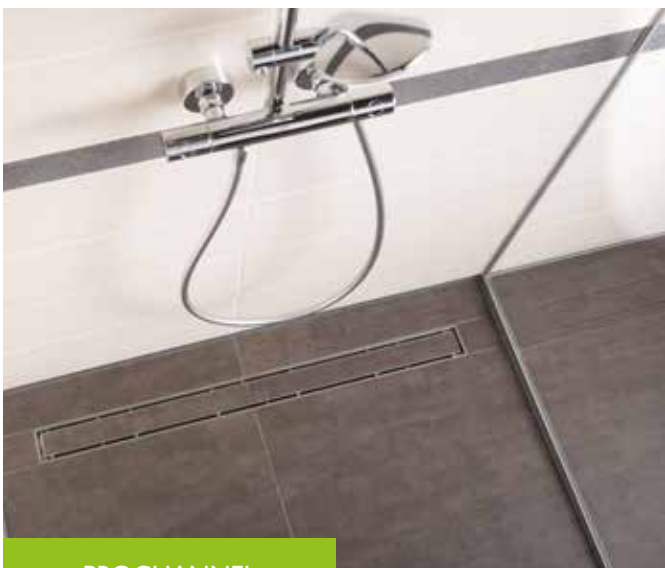

PROCHANNEL  
with tile recess

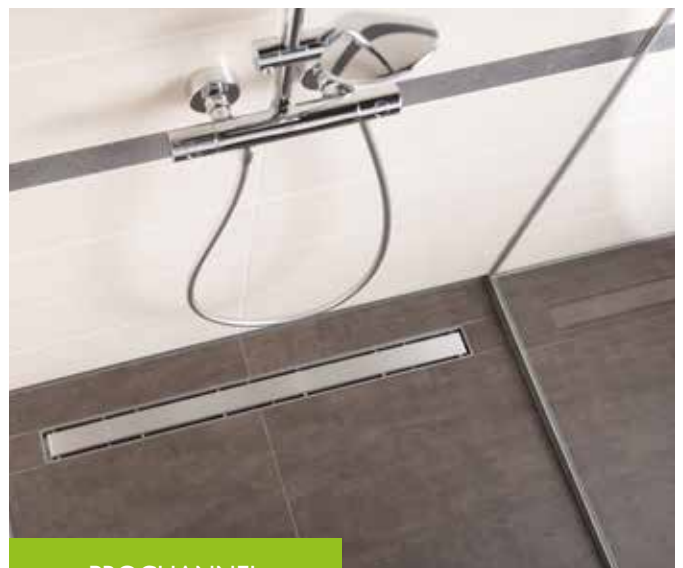

PROCHANNEL  
with design grille Steel



PROCHANNEL  
with design grille Classic



Design grille  
Flower



Design grille  
Linear



Design grille  
Cross



Design grille  
ZigZag

## Drainage line lengths

### PROCHANNELp-line

The PROCHANNELp-line is available in the following lengths:

#### Drainage line housing for tiles

Nominal length (mm)	700	800	900	1000	1200	1500
Dim. in unfinished state incl. flange (mm)	711	811	911	1011	1211	1511
Visible dim. after installation (mm)	651	751	851	951	1151	1451

#### Natural stone drainage line housing includes recess

Nominal length (mm)	800	900	1000
Visible dim. after installation (mm)	750	850	950

Due to the special design, the PROCHANNELp-line can be made to a special design based on customer requirements. We can offer you the following special solutions

- Special lengths
- Decentralised drain
- Corner drain training

### PROCHANNELs-line

The PROCHANNELs-line is available in the following lengths:

#### Drainage line housing

Nominal length (mm)	500	600	700	800	900	1000
Dim. in unfinished state incl. flange (mm)	539	639	739	839	939	1039
Visible dim. after installation (mm)	452	552	652	752	852	952

#### PROCHANNELs-line with support element for creating a shadow gap

The PROCHANNELs-line support element is the perfect alternative for instances when the floor covering needs to be on display without any distracting border. The tile is properly bonded to the support element to form a shadow gap.

The support element is inserted directly into the PROCHANNELs-line drainage line; the use of the frame is not necessary.



PROCHANNELs-line with support element

## Accessories in the system

Tested sealing system: PROFOLIO with PROFIX DS

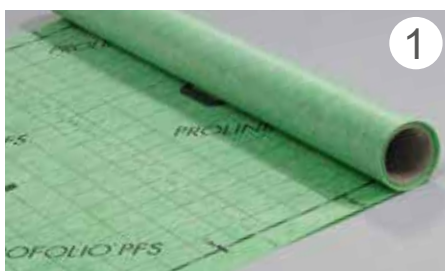
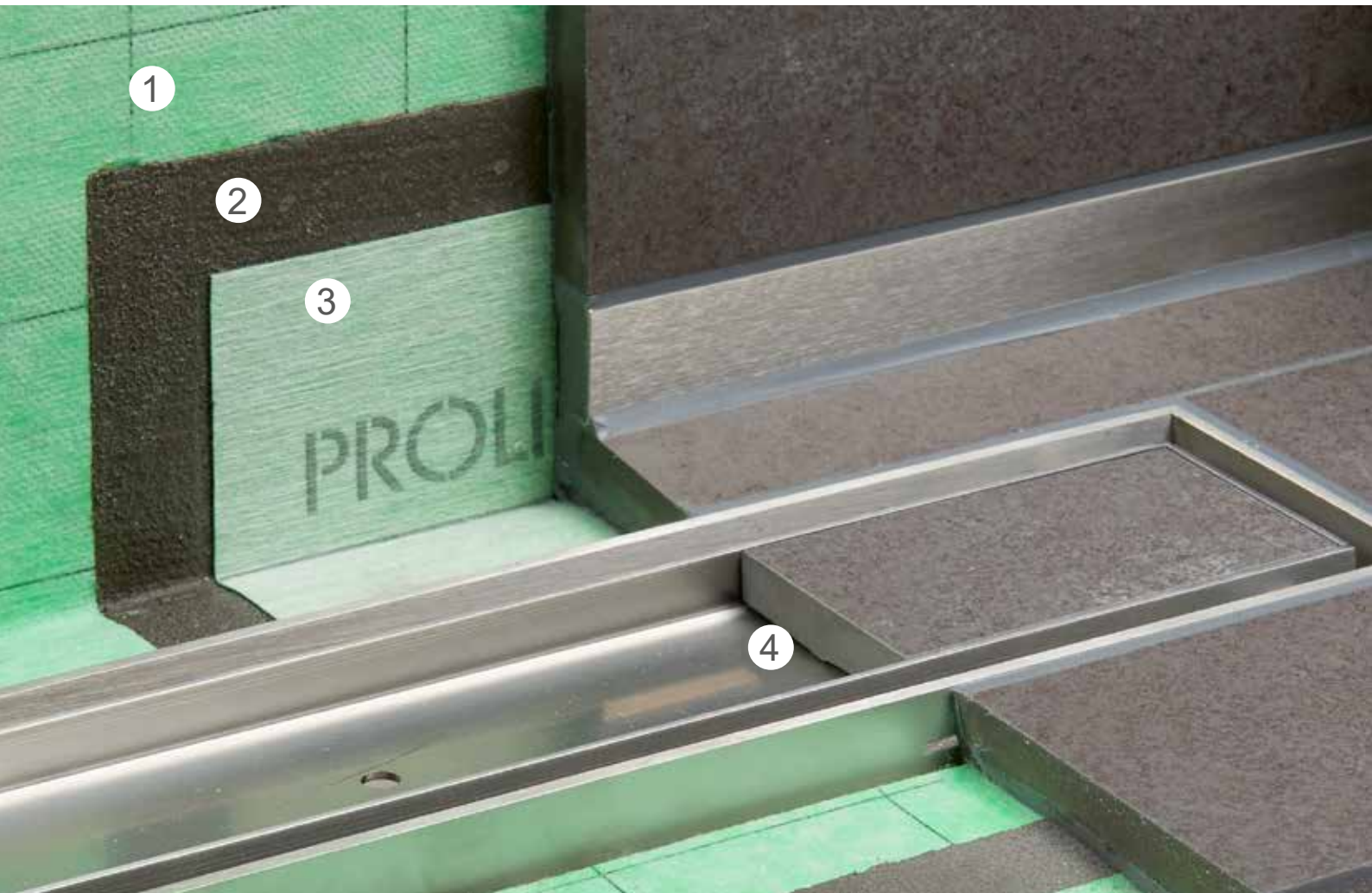

PROFOLIO sealing and decoupling membrane made of polyethylene



PROFIX DS sealing slurry



PROFOLIO sealing tape in the PROFOLIO system



OTTOCOLL M500  
hybrid adhesive and sealants

The adhesive OTTOCOLL M500 tested in system is designed to adhere

- pipe collars to drainage line housings
  - tiles/natural stone in tile recesses
  - tiles/natural stone on support elements
- and it is recommended by us.

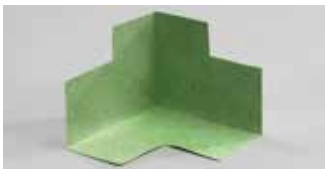

PROFOLIO sealing tape corners  
Internal corner

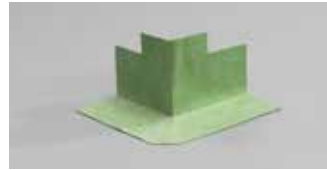

External corner

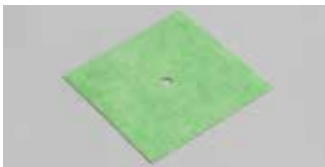

PROFOLIO pipe collars  
Wall collar



Floor collar



PROFOLIO  
butt-joining tape



PROFIX  
dispersion fixative

## Ergänzungsprodukte



PROFOLIO tub sealing tape  
with cut and noise insulation  
design



PROFOLIO tub sealing tape  
with noise insulation design



PROBAND  
butyl sealing tape,  
self-adhesive



PROFOLIO compensation corner  
compensation corner left



compensation corner right

**Accessories**

PROCHANNEL *p-line* & PROCHANNEL *s-line*





PROCHANNEL  
class carrier profile



PROCHANNEL  
slope profile

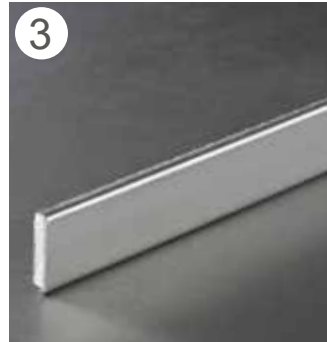

PROCHANNEL  
wall cover

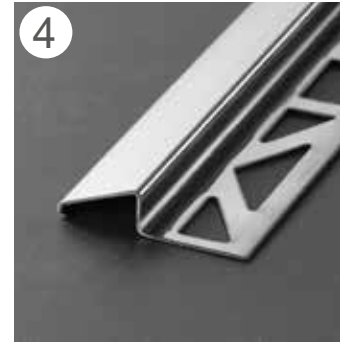

PRONIVO S  
transition and  
compensator profile



PROCHANNEL hair sieve



PROCHANNEL  
installation feet

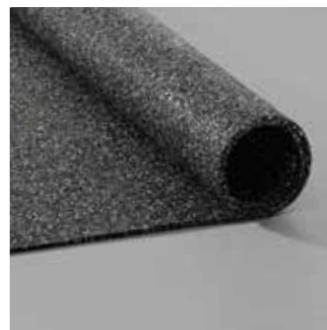

PROCHANNEL  
sound insulation mat

The individual accessory products fit together perfectly and ensure the best results:  
The slope profile is available in a left-hand or right-hand design and can easily be inserted into a glass carrier profile.



# Everything close to hand

## PROSHELF

Thanks to PROSHELF the customer's requirement to have everything close to hand in the shower can be achieved very simply. No more awkward bending down in the shower for shampoo, etc. Anywhere a shelf is not built-in, the installer can now do this

with the help of PROSHELF. The tileable shower shelf can even be installed retrospectively without damaging the tiles, by being slotted into the available joint.

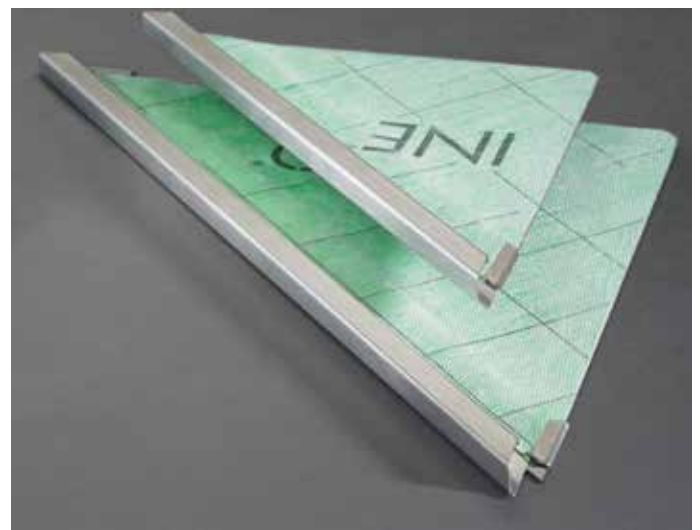
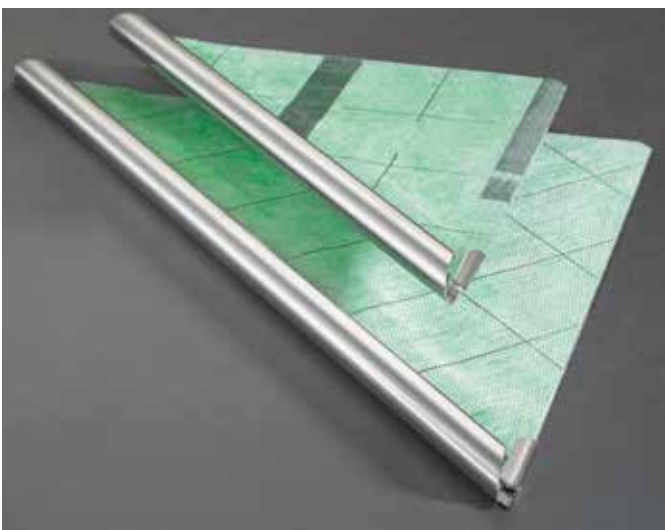

### PROSHELF with PROROUND

The round-edged profile, PROROUND, forms the basis for this PROSHELF variant. An elegant result thanks to the rounded face edge, which succeeds the tile profiles from the PROROUND series.

### PROSHELF with PRODECOR Q

The face edge of PROSHELF and PRODECOR Q is pragmatic and above all, square. Surely the first choice for modern architecture and bathroom design, as it goes excellently with the styling and straight lines of modern tiles in the bathroom area.

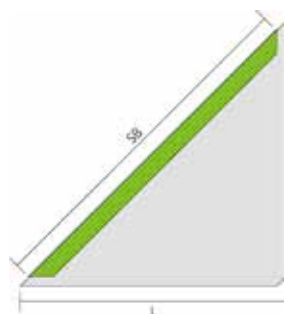

- Visible widths (SB): 29 and 40 cm
- Edge lengths (L): 21 and 28 cm
- Profile heights: 8, 10, 11 and 12.5 mm
- Versions:
  - Stainless steel brilliant
  - Stainless steel brushed
  - Stainless steel chrome-plated

## Advantages of PROSHELF

- Areas of use:  
New builds and renovations
- Versatile design options:  
2 sizes  
2 profile versions (round-edged or square profile)  
3 stainless steel surfaces  
4 different heights  
Tile flooring can be built-in
- Simple to process:  
Can be used in any tiled shower
- System concept:  
Profiles suitable for the Proline collection



# POS sales promotion

## PROCHANNEL<sub>p</sub>-line & PROCHANNEL<sub>s</sub>-line

### Checklists

Our extensive PROCHANNEL checklists help you select and compile the modular components you need for every project. You can download the right checklist for your needs at any time on our website.

### Brochures & flyer

Our product line brochures provide you with a first guide to our wide range of products. Ask your dealer – or use our online download offer.

### Displays

To support your on-site consulting services, we provide distinctive displays showcasing the original installation of our PROCHANNEL components. In addition we offer you 10 additional exhibits (e.g. PROFOLIO) which can be displayed on our premium collection presenter.

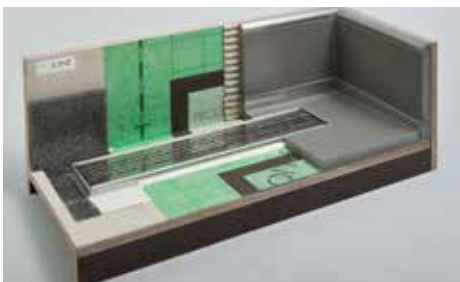

PROCHANNEL<sub>p</sub>-line with design grille  
Item No.: M31469 (Size: 508 x 210 x 198 mm)

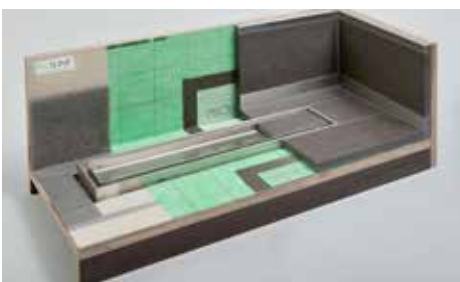

PROCHANNEL<sub>s</sub>-line with tile recess  
Item No.: M31468 (Size: 508 x 210 x 198 mm)



PROCHANNEL<sub>s</sub>-line with support element  
Item No.: M31471 (Size 508 x 210 x 198 mm)

## The application video for professionals

### PROCHANNEL Linear drainage

Our application videos guide you step-by-step to flawless finished installation. You can use the QR code shown to view the videos directly on your smartphone.



You Tube





**Proline Systems GmbH**

Kratzenburger Landstraße 11-15  
Industriegebiet Hellerwald  
56154 Boppard – Germany

Tel. +49 (0) 67 42 / 80 16-0  
info@proline-systems.com  
www.proline-systems.com

Follow us on:

